

Aluminum Railing Installation Guide

- TOOLS & MATERIALS NEEDED -

TOOLS :

- Hacksaw or metal cutting saw
- Drill
- 3mm, 4mm Drill bit
- Screwdrivers
- Measuring tape

MATERIALS :







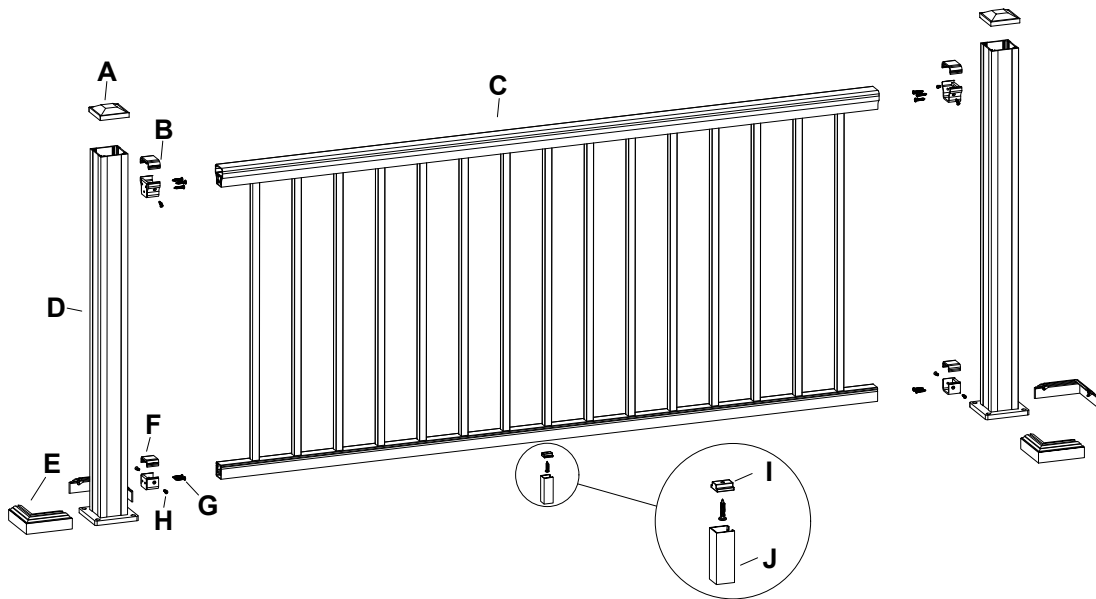



- Post Kits
- Panel Kits
- Brackets Kits
- Fasteners are included with each components

- Straight Railing -

Aluminum Straight Railing - Parts



Material List - Aluminum Straight Railing

Code	Qty	Description
A 	x2	Post Cap
B 	x2	Top Rail Bracket
C 	x1	Pre-assembled Railing
D 	x2	Post
E 	x2	Post Trim
F 	x2	Bottom Rail Bracket
G 	x11	#10-25mm Self-drilling stainless steel screws
H 	x8	#8-20mm Self-drilling stainless steel screws
I 	x1	Bottom Rail Support Connector
J 	x1	Bottom Rail Support

Aluminum Railing Installation Guide

Straight Railing Installation

1 Measure and locate all the posts.

1.1 Measure and locate all the posts.

1.2 Choose the appropriate fasteners to fasten the posts according to local building codes.

Ensure the posts are plumb. Use the provided shims to adjust the verticality. The internal spacing between posts is 1829mm or 2438mm if full sections are used.

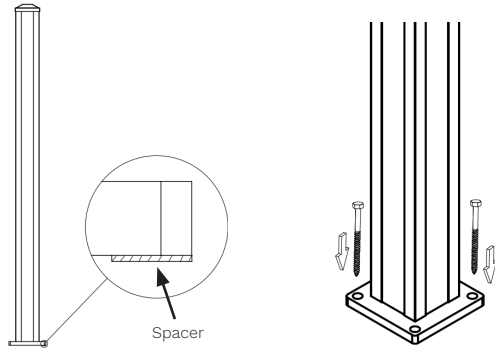

2 Install the Bottom Brackets and Top Brackets.

Note: Pre-drill screw holes with 4mm drill bit when installing the brackets. Use the supplied #10-25mm pan head screws for the bracket.

2.1 Use the cardboard template to locate the screw holes position. Put it in place, as shown in the below diagram. Then use a pencil to mark the position of the Screw holes.

2.2 Install the brackets to the post with #10-25mm screws.

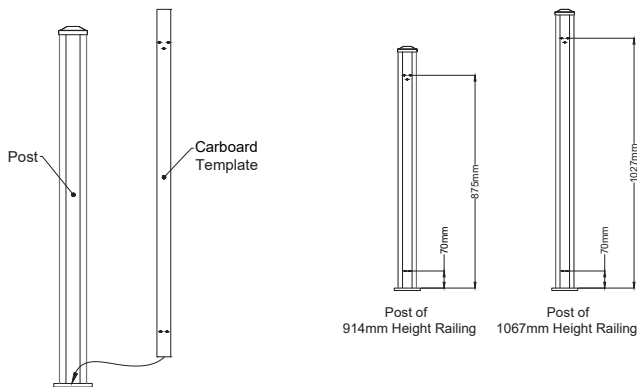

3 Install the Bottom Rail Support Connector.

3.1 Mark the position of the bottom rail support connector. For a 1829mm railing, the position should be in the middle of the Bottom Rail; For a 2438mm railing, the distance between the bottom rail support connector to the ends of the bottom rail should be 752mm on each side.

3.2 Install the bottom rail support connector with a #10-25mm screw.

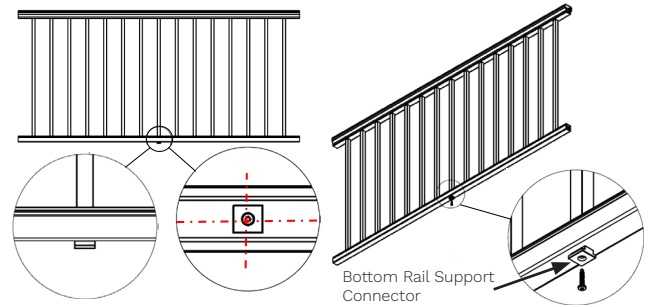

Note: For shorter sections, Remove an additional 8mm on both ends (16mm overall) for the bracket to fit between the rail and post. Trim the top and bottom rails to length.

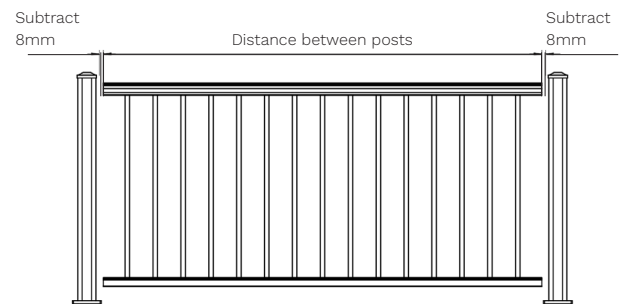

4 Install the Pre-assembled panel to Brackets.

4.1 Insert the bracket cover into the ends of rail.

4.2 Set the top and bottom rail into the bracket. Secure the bracket to the rail using (2) #8-20mm flat head self-drilling screws.

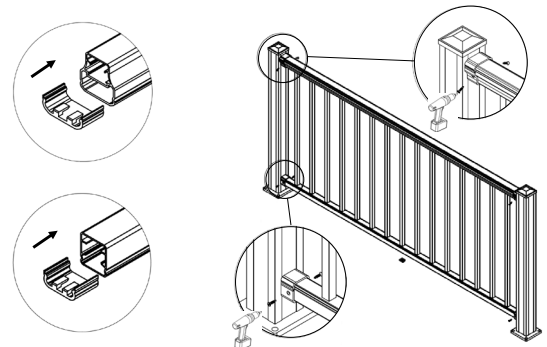

5 Install the Bottom Rail Support.

5.1 Install the bottom rail support to the bottom rail support connector with a rubber hammer.

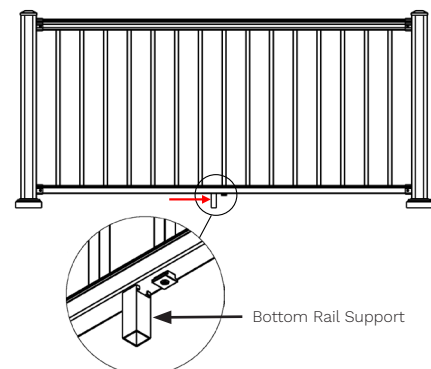







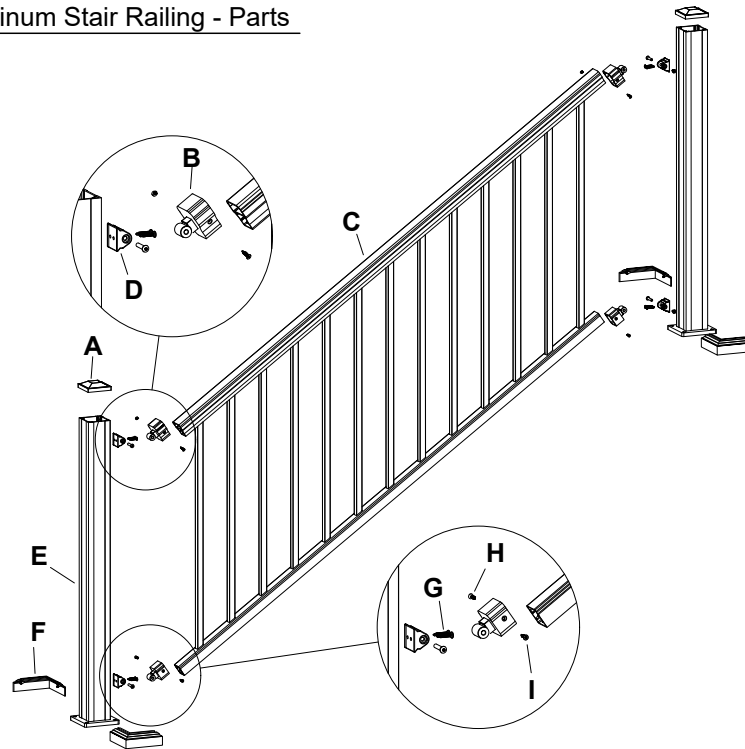

Aluminum Railing Installation Guide

- Stair Railing -

Aluminum Stair Railing - Parts



Material List - Aluminum Stair Railing

Code	Qty	Description
A 	x2	Post Cap
B 	x2	Stair Bracket-Top Rail
C 	x1	Pre-assembled Stair Railing
D 	x4	Stair Bracket Base & Fixing Rivet
E 	x2	Post
F 	x2	Post Trim
G 	x8	#10-25mm Self-drilling stainless steel screws
H 	x8	#8-20mm Self-drilling stainless steel screws
I 	x2	Stair Bracket-Bottom Rail

Aluminum Railing Installation Guide

Stair Railing Installation

1 Locate all the posts.

1.1 Ensure the posts are plumb. Use the provided shims to adjust the verticality.

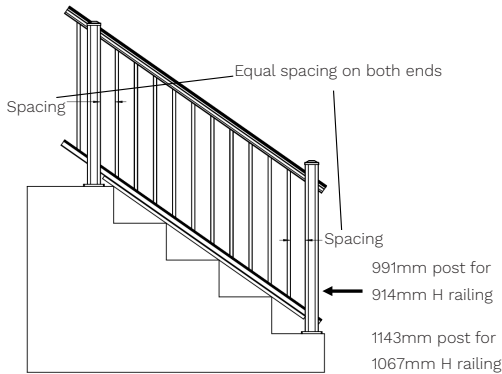

Note: During installation, please don't tilt the railing to the maximum angle repeatedly as this will scratch the powder coating on the pickets.

2 Mark the position of the Stair Brackets.

2.1 The distance between the post and the first picket should be less than 102mm and equal spacing on both ends.

2.2 Once the railing is in position, clamp the railing to the posts.

2.3 Temporarily assemble the swivel brackets. Position the swivel bracket in location and mark the position on the rails and posts.

2.4 Mark the cutting mark for the top rail and bottom rail, as shown in Note 1.

2.5 Cutting the top rail and bottom rail.

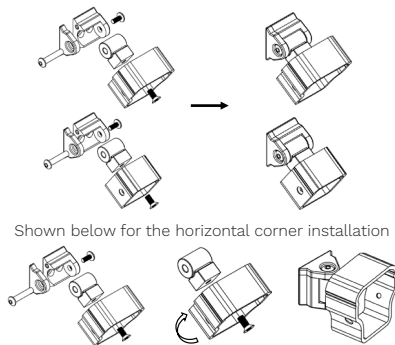

Note 1: Add 25mm from mark when cutting rails.

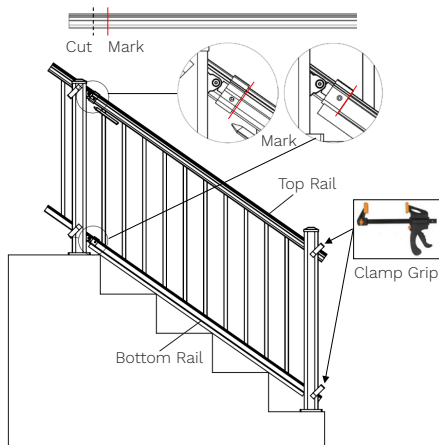

3 Install the Stair Bracket Base.

3.1 Install the stair bracket base to the post with #10-25mm screws.

3.2 Install the brackets to the post with #10-25mm screws.

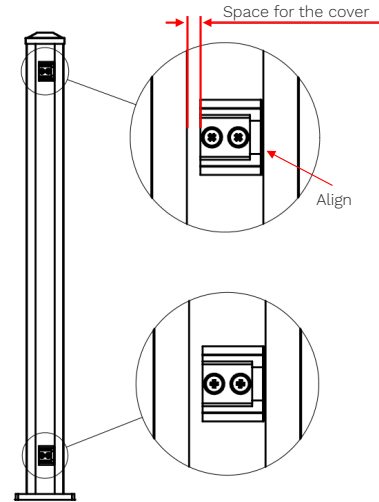

4 Install the railing and brackets.

4.1 Set the top and bottom rail into the bracket with #8-20mm flat head self-drilling screws. Fasten the bracket to the bracket base using the rivet.

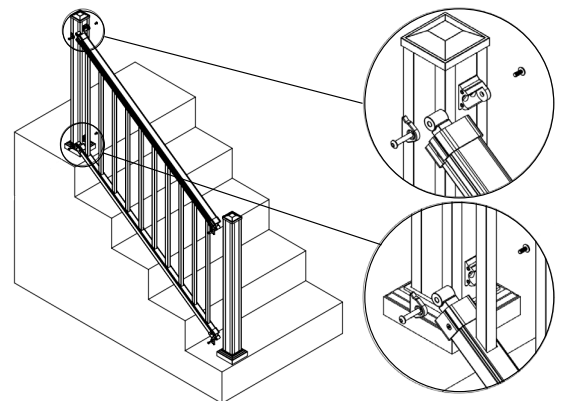

Install the Post Cap and the Post Trim

Install the post cap and post trim after all other components are installed.

The post cap locks into the post by using a rubber hammer or similar tool until it is tightened.

Install the post trim as follows:
Apply glue to the holes of the post trim (do not overflow)
Assemble 2 sides of the post trim and press it together for approximately 6 seconds.

